

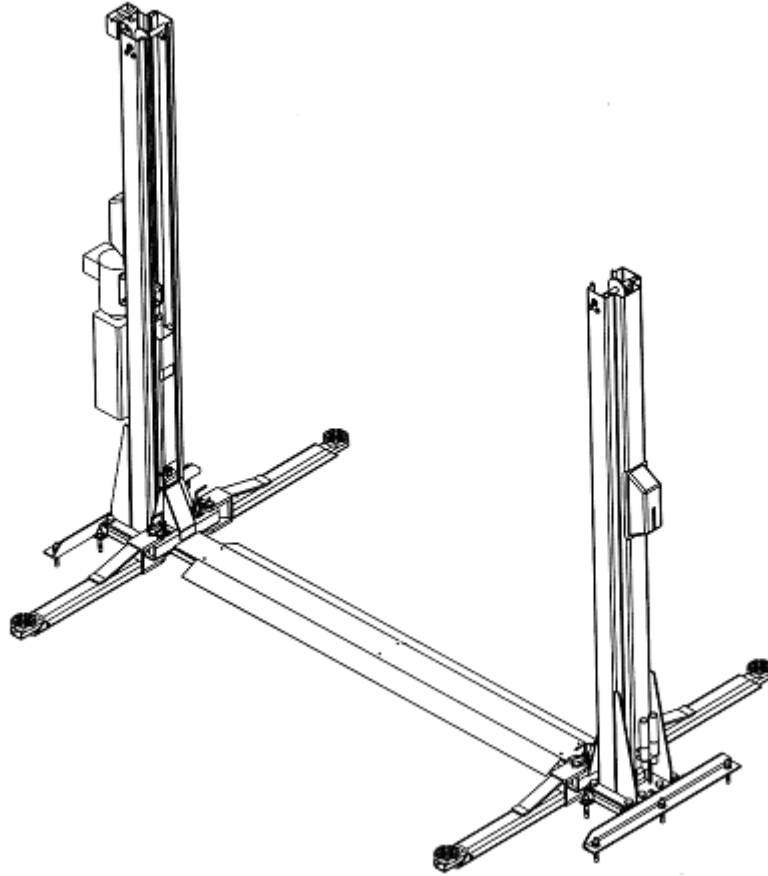

INSTALLATION and OPERATION MANUAL



MODEL EELR335A
9,000 LB. CAPACITY

**READ and SAVE THIS
INSTRUCTION MANUAL**



Snap-On Tools Corporation
1-800-268-7959

OCT 2005

6-2567

TABLE OF CONTENTS	PAGE
1 SAFETY AND OPERATING INSTRUCTIONS	1
2 SPECIFICATIONS.....	2
3 CONTENTS.....	3
4 INSTALLATION REQUIREMENTS AND TOOLS	3
5 INSTALLATION INSTRUCTIONS	4
5.1 UNPACKING PROCEDURE	4
5.2 BAY LAYOUT.....	5
5.3 TOWER POSITIONING AND SETUP.....	6
5.4 HYDRAULIC CONNECTIONS	7
5.5 LIMIT SWITCH INSTALLATION	7
5.6 POWERPACK INSTALLATION	8
5.7 AIR SAFETY INSTALLATION.....	9
5.8 ROUTING OF EQUALIZATION CABLES	10
5.9 ARM INSTALLATION	11
5.10 HYDRAULIC SYSTEM BLEEDING.....	12
5.11 TOWER POSITIONING AND ANCHORING	13
6 PERIODIC MAINTENANCE.....	14
7 SAFETY AWARENESS - AUTOMOTIVE LIFT INSTITUTE (ALI).....	14
8 PARTS MANUAL	15
8.1 LIFT ASSEMBLY	15
8.2 LIFT ASSEMBLY PARTS LIST	16
8.3 HYDRAULIC SYSTEM	18
8.4 HYDRAULIC SYSTEM PARTS LIST	19
8.5 HYDRAULIC CYLINDER	19
8.6 HYDRAULIC CYLINDER ASSEMBLY PART LIST.....	20
8.7 AIR SYSTEM.....	21
8.8 AIR SYSTEM PART LIST.....	22
8.9 POWER PACK.....	23
8.10 POWER PACK PARTS LIST.....	24
8.11 LIFT MAINTENANCE GUIDELINES - CABLE EQUALIZATION.....	25

1 SAFETY AND OPERATING INSTRUCTIONS

1. When using this lift, basic safety precautions should always be followed, including the following.
2. Read all instructions in this manual and on the lift.
3. Inspect lift daily. Do not operate if it malfunctions or problems have been encountered.
4. Never attempt to overload the lift. The manufacturer's rated capacity is shown on the identification label on the power side column. Do not override the operating controls or the warranty will be void.
5. Before driving vehicle between the towers, position the arms to the drive-through position to ensure unobstructed clearance. Do not hit or run over arms as this could damage the lift and/or vehicle.
6. Only trained and authorized personnel should operate the lift. Do not allow customers or bystanders to operate the lift or be in the lift area.
7. Position the lift support pads to contact the vehicle manufacturers recommended lifting points. Raise the lift until the pads contact the vehicle. Check pads for secure contact with the vehicle. Check all arm restraints and insure they are properly engaged. Raise the lift to the desired working height.
8. Some pickup trucks may require an optional truck adapter to clear running boards or other accessories.
NOTE: Always use all 4 arms to raise and support vehicle.
9. **Caution! Never work under the lift unless the mechanical safety locks are engaged.**
10. Note that the removal or installation of some vehicle parts may cause a critical load shift in the center of gravity and may cause the vehicle to become unstable. Refer to the vehicle manufacturer's service manual for recommended procedures.
11. Always keep the lift area free of obstruction and debris. Grease and oil spills should always be cleaned up immediately.
12. Never raise vehicle with passengers inside.
13. Before lowering check area for any obstructions.
14. Before removing the vehicle from the lift area, position the arms to the drive-through position to prevent damage to the lift and /or vehicle.

2 SPECIFICATIONS

Capacity:
 Overall Width (incl. powerpack):
 Width Between Columns:
 Drive-Thru Width:
 Overall Height:
 Baseplate Height:
 Height to Lowered Lift Pads:
 Height to Lift Pad (3" Adapter):
 Height to Lift Pad (6" Adapter):
 Retracted Arm Length:
 Extended Arm Length:
 Maximum Lifting Height (6" Adapter):
 Lift Time:
 Power Requirements (Standard):

9000 lbs.	4080 kg
151 3/4"	3855 mm
118 1/2"	3010 mm
109"	2769 mm
120"	3048 mm
2"	51 mm
4"	102 mm
7"	178 mm
10"	254 mm
35 1/4"	895 mm
53 1/2"	1359 mm
78'	1981 mm
45 seconds	
230 Volts AC, 1 Ph., 60Hz.	

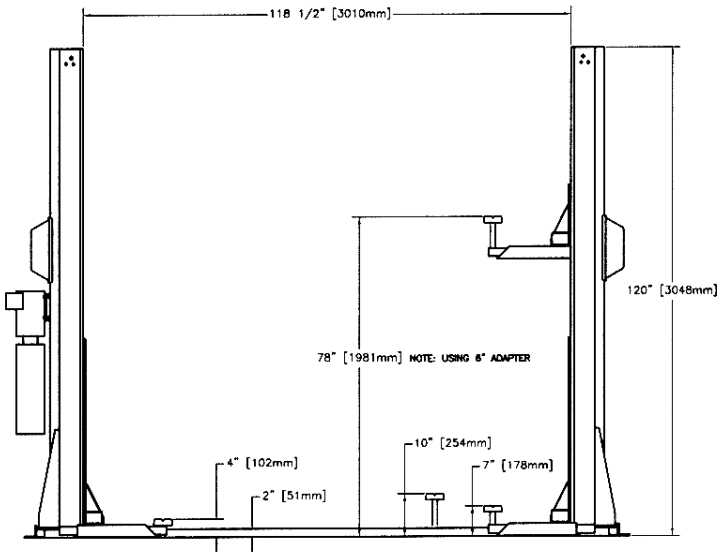

Figure 1 – Front View

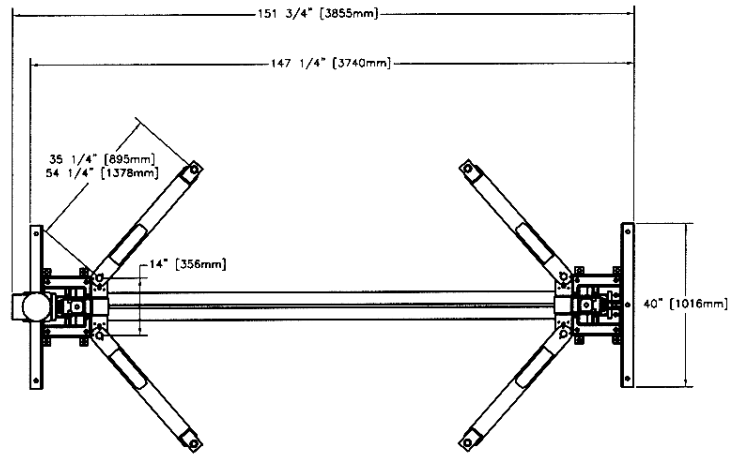

Figure 2 – Top View

3 CONTENTS

The complete lift is contained in three (3) packages:

1. The towers are packed in a steel frame
2. The baseframe and line covers are packed on a skid
3. The remaining parts are packed in an **accessory box**.

Tower Components include:

- 1pc. - Power side tower and carriage assembly
- 1pc. - Slave side tower and carriage assembly

Baseframe Components include:

- 1pc. - Baseframe weldment
- 1pc. - Linecover

The accessory box has its own packing slip listing contents.

4 INSTALLATION REQUIREMENTS AND TOOLS

IMPORTANT: It is the user's responsibility to provide a satisfactory installation area for the lift. Lifts should only be installed on level concrete floors with a minimum thickness of five (5) inches or 130 mm. Concrete must have a minimum strength of 4000 psi or 30 MPa and should be aged thirty (30) days prior to installation. Please consult the architect, contractor or engineer if doubt exists as to the strength and feasibility of the floor to enable proper lift installation and operation.

It is the user's responsibility to provide all wiring for electrical hook-up prior to installation and to insure that the electrical installation conforms to local building codes. Where required, it is the user's responsibility to provide an electrical isolation switch located in close proximity to the lift that will enable emergency stop capability and isolate electrical power from the lift for any servicing requirements.

Tools Required:

- a. 16ft. Measuring Tape
- b. Chalk Line
- c. Rotary Hammer Drill
- d. 3/4" diameter Masonry Drill Bit
- e. Hammer
- f. SAE Wrenches and Ratchet Set
- g. 2ft. Level
- h. 4ft. Level
- i. Crow Bar
- j. 12ft. Step Ladder
- k. Side Cutters
- l. Screwdrivers
- m. 4" x 4" Wooden Blocks (for unpacking)

5 INSTALLATION INSTRUCTIONS

When the lift arrives on site:

- Read the owner's manual and make sure the installation instructions are fully understood.
- Check for any freight damages.
- Check the contents of the accessory and hardware boxes to make sure no parts are missing.
- Gather all the tools listed above.

5.1 UNPACKING PROCEDURE

1. **Important!** Place the main structural components on wooden blocks so that the steel shipping frames can be removed.
2. Remove the plastic wrapping.
3. Unbolt the steel shipping frames.
4. Lay each tower on the floor with the carriage side up.
5. Unpack the crossmember and line covers
6. Check the installation area for obstructions. (Lights, Heating Ducts, Ceiling, Floor Drains, etc.)
7. Prepare the bay by selecting the location of the lift relative to the walls. Clear the installation area of all packaging materials to avoid trip hazards. Draw a chalk line on the floor to represent the centerline of the bay then draw a second chalk line at 90° for locating the lift towers. Refer to **Figure 3**.

5.2 BAY LAYOUT

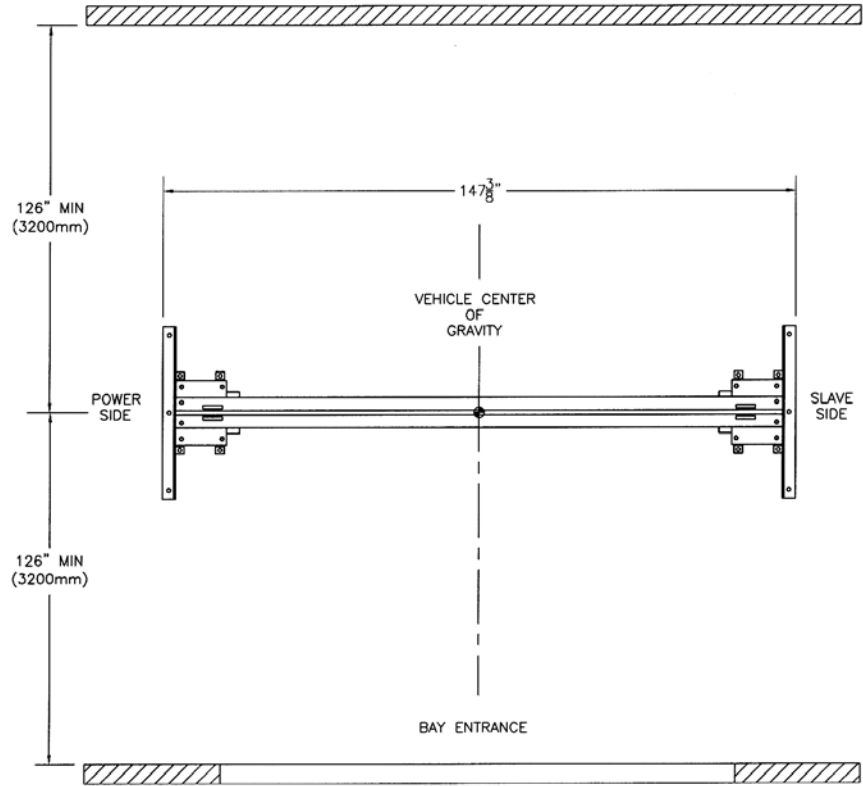
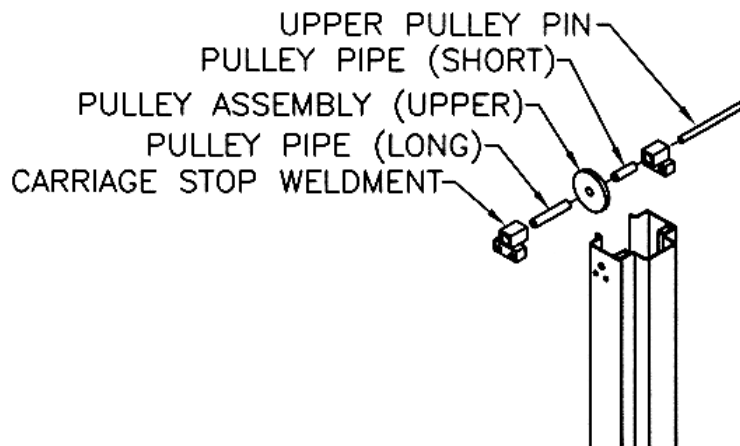

Figure 3 – Bay Layout

5.3 TOWER POSITIONING AND SETUP

1. Locate the baseframe weldment as shown in **Figure 3**. Use the shims in the hardware kit to ensure that the base is level in all directions.
2. Locate the power side and slave side towers and position them on the baseframe as shown in **Figure 3**. Note: the power side has a mounting bracket for the powerpack welded to the back of the crossmember.
3. Anchor the towers to the baseplate using the $\frac{3}{4}$ "-NC hex bolts and $\frac{3}{4}$ " lock washers found in the hardware kit. At this point, only screw the bolts in as far as the first few threads. This is important, as some adjustment of the towers may be necessary when making the hydraulic connections.
4. Lift the carriages up and rest them on the first safety.
5. Assemble the upper pulley assemblies using the upper pulley pin, pulley pipe (long – approx 3 $\frac{1}{2}$ "), pulley pipe (short – approx 1"), and carriage stop weldments (all items found in the accessory box). When looking at the open front of the tower, the short spacer should always be on the left of the pulley, and the long spacer should be on the right of the pulley. The flat washers should go on the outside of the tower.



6. Slide the pulley assemblies into the top of the tower and install the carriage stop weldments using the $\frac{1}{2}$ "-NC x 2 $\frac{1}{4}$ " hex bolts, $\frac{1}{2}$ " flat washers, $\frac{1}{2}$ " lock washers, and $\frac{1}{2}$ "-NC hex nuts located in the hardware kit (see figure below)

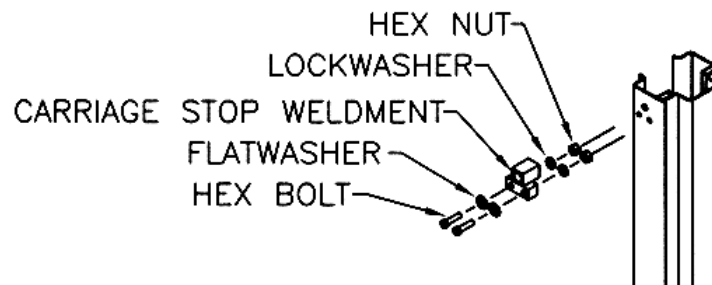

5.4 HYDRAULIC CONNECTIONS

NOTE: REFER TO THE HYDRAULICS SYSTEM SHOWN IN THE PARTS LIST.

1. Connect the long leg of the 9 ½” steel hydraulic tube (with the 90 degree bend) in-line to the 3/8” JIC union T. Both items are found in the accessory box.
2. Feed the tube and union T under the driver side tower, in between the crossmember tubes of the baseframe. The short leg at 90 degrees should come out of the opening at the back of the tower. If necessary use electrical tape to keep the cap at the end of the short leg of the tube while feeding the assembly under the tower.
3. Connect the 3/8” JIC union adapter (found in the accessory box) to the short leg of the 9 ½” hydraulic tube. Connect the straight end of the short flex hose (found in the accessory box) to the other end of the 3/8” JIC union adapter.
4. Remove and discard the caps from the flow control at the base of each cylinder.
5. Connect one end of the long flex hose (found in the accessory box) in-line to the 3/8” JIC union T.
6. Use one of the 2 5/8” steel hydraulic tubes to connect the driver side cylinder to the final port on the 3/8” JIC union T.
7. Run the long flex hose to the opposite tower in between the baseframe crossmembers.
8. Connect the 3/8” JIC elbow to the second 2 5/8” hydraulic tube (both items found in the accessory box). Connect the opposite end of the elbow to the free end of the long flex hose. Connect the remaining end of the 2 5/8” steel hydraulic line to the flow control on the passenger side cylinder.

5.5 LIMIT SWITCH INSTALLATION

1. Screw the microswitch assembly (located in the accessory box) to the inside of the protective guard on the top of the driver side tower.
2. Install the rocker arm (located in the hardware kit) on the driver side tower using the limit switch pin and two snap rings (located in the hardware kit). Refer to Figure 4
3. Place the electrical cable clips (located in the hardware kit) on the tower to run the electrical line from the microswitch to the powerpack.

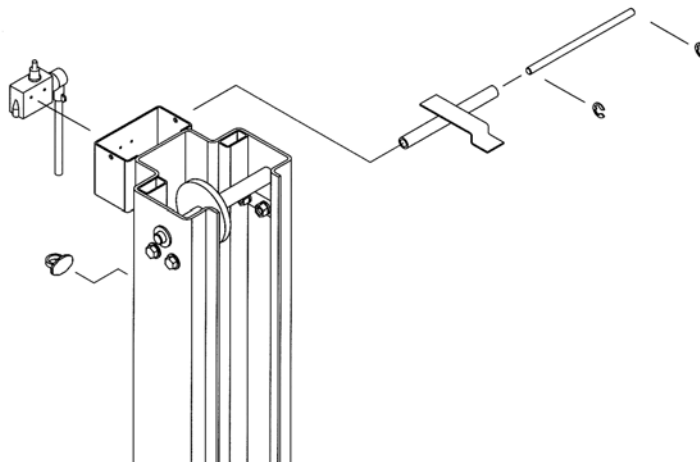
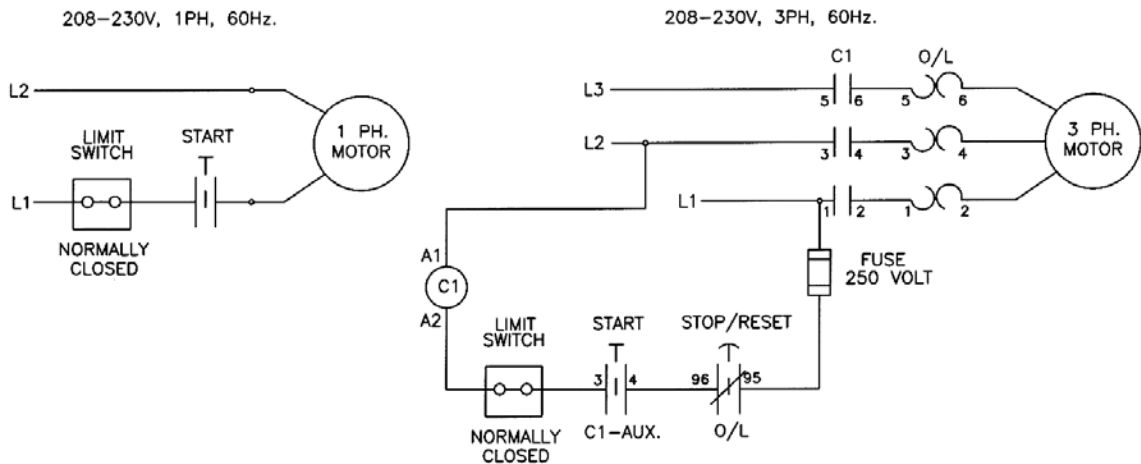

Figure 4 – Limit Switch Installation

5.6 POWERPACK INSTALLATION

1. Remove and discard the red plastic cap located at the rear of the power pack, and install the 90 degree elbow (JIC to SAE) located in the hardware kit.
2. Bolt power pack to the mounting bracket on the power side tower using four (4) 5/16"-18UNC x 1"LG. hex head bolts, four (4) 5/16" ID lock washers, four (4) 5/16" ID flat washers and four (4) 5/16"-18UNC hex nuts (found in the hardware kit).
3. Connect the short flex hose to the 90 degree elbow.
4. Fasten the short flex hose to the tower using the hose clamp, 1/4" lock washer, an 1/4"-NC x 3/8" round head screw (located in the hardware kit).
5. Remove the filler cap from the powerpack and fill the reservoir with approximately 4.5 Gal. (18L) of ISO32 hydraulic oil (10 wt. hydraulic oil). Remove breather screw when filling and replace when full.
6. A **certified electrician** must connect the 230Volt/1Ph power to the motor. The electrical diagram is provided, refer to



7. **Figure 6.**

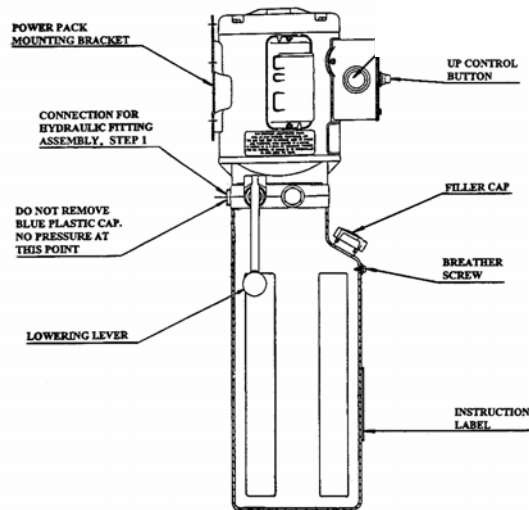

Figure 5 – Powerpack Details

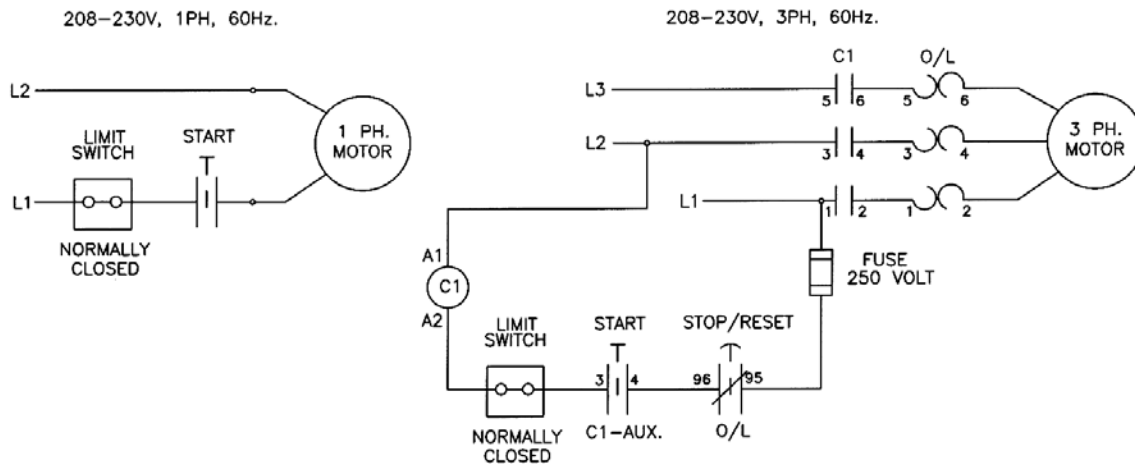

Figure 6 – Electrical Diagram

5.7 AIR SAFETY INSTALLATION

NOTE: WHEN CUTTING POLYTUBE BE SURE TO CUT THE LINE AT NINETY DEGREES. FAILURE TO DO SO MAY RESULT IN LEAKS IN THE AIR CONNECTIONS.

1. Pull the red pushbutton off the air valve and filter assembly (found in the accessory box) and unscrew the plastic jam nut. Place the assembly on the motor mount bracket and fasten it using the plastic jam nut. Replace the red pushbutton.
2. Cut a short (2" LG) piece of 4mm polytube and connect it to the air valve. Attach the 4mm union T (located in the hardware kit) to the end of the polytube.
3. Attach the rod clevises to the air cylinders (found in the hardware kit).
4. Attach the 90 degree push lock elbows to the air cylinders.
5. Attach the air cylinders to the safety bracket weldments using the 5/16"-NC X 3/4" shoulder bolts found in the hardware kit. These should go through the base of the cylinder.
6. Connect the opposite end of the air cylinders (rod clevises) to the safety dogs using the 5/16"-NC x 1 1/4" shoulder bolts.
7. Run the 4mm polytube through the hole in the R.S. safety cover and connect it to the air cylinder on the passenger side. Attach the R.S. safety cover to the tower.
8. Run the 4mm polytube down the tower and through the cutout in the back of the tower baseplate. Run the polytube between the crossmember tubes to the driver side tower. Feed the polytube under the driver side tower and up through the cutout in the back of the tower. Run the polytube up to the union T at the air valve, cut the air line at this point and connect it to the union T.
9. Run another piece of 4mm polytube through the hole in the L.S. safety cover and connect it to the air cylinder on the driver side tower. Attach the L.S. safety cover to the driver side tower. Run the polytube down to the union T and connect it to the remaining port (Trim excess polytube as required).
10. Connect the shop air supply to the air valve and filter assembly.

5.8 ROUTING OF EQUALIZATION CABLES

1. Run the lift up to full stroke and lower the carriages onto the top safety. Note: the carriages may not go up together at this point, but continue to power up until both carriages have reached the top.
2. Run the threaded end of the first equalization cable down the back right side of the driver side carriage and feed it through the cable boss at the bottom of the carriage. Pull the rest of the cable through the carriage so that the button at the end of the cable butts up against the cable boss. Feed the cable through the cutout in the tower baseplate and run it through the hollow structural tube to the opposite side. Fish the threaded end of the cable out of the opening in the opposite tower baseplate. Feed the cable up through the back left hand side of the carriage and let it hang freely over the top of the carriage. Repeat this procedure with the second cable starting at the passenger side tower.
3. Use the $\frac{3}{4}$ " diameter pins and snap rings located in the hardware kit to attach 2 pulleys to each tower weldment (on the post below the cylinder). Make sure that the cables run freely under the pulleys and that a thrust washer is placed between each pulley and the cylinder post.
4. Take the threaded end of each cable and run it up the tower, over the pulley at the top of the tower, and back down to the carriage. The threaded end should be fed through the cable boss on the top left side of the carriage and the $\frac{1}{2}$ " locknut should be tightened until all slack has been removed (use vise grips to hold the square portion of the threaded stud).
5. Using the #12 self threading screws (found in the hardware kit), fasten the line covers to the baseplate.

5.9 ARM INSTALLATION

1. Raise the lift, press the air safety release and lower the lift to the ground.
2. Remove the arm assemblies from the accessory box and place one arm at each corner of the carriages.
3. Remove the four (4) 5/16"-18UNC x 3/4"LG. hex head bolts that are holding the arm pins to the arm. Install the arms on the carriages.
4. Grease and insert arm pins. Align the notch on each arm pin with the tapped hole on the arm, and using the 5/16"-18UNC x 3/4"LG. hex head bolt removed in previous step, reinstall and tighten securely.
5. Using two (2) 5/16"-18UNC x 1 1/4" LG. hex head bolts and two (2) 5/16" flat washers, attach each arm restraint gear as shown in **Figure 7**.

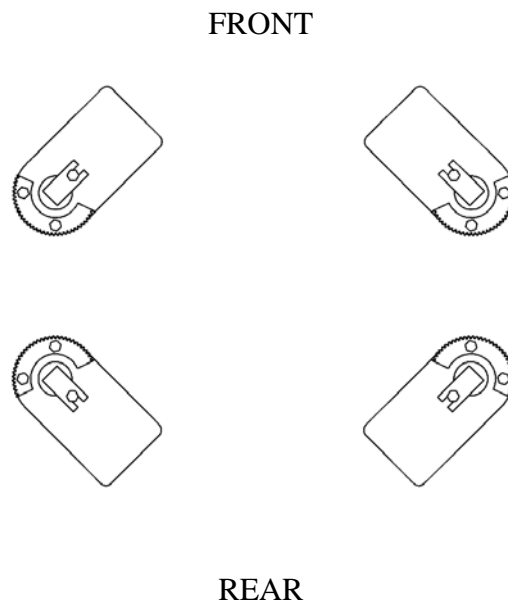

Figure 7 – Arm Installation

6. Using two (2) 3/8"-16UNC x 1" LG. socket head cap screws, and two (2) 3/8" ID lock washers, install the arm restraint assemblies as shown in **Figure 8**. Before tightening completely, make sure that the arm restraint has full contact with the arm restraint gear by pushing it firmly against the arm.

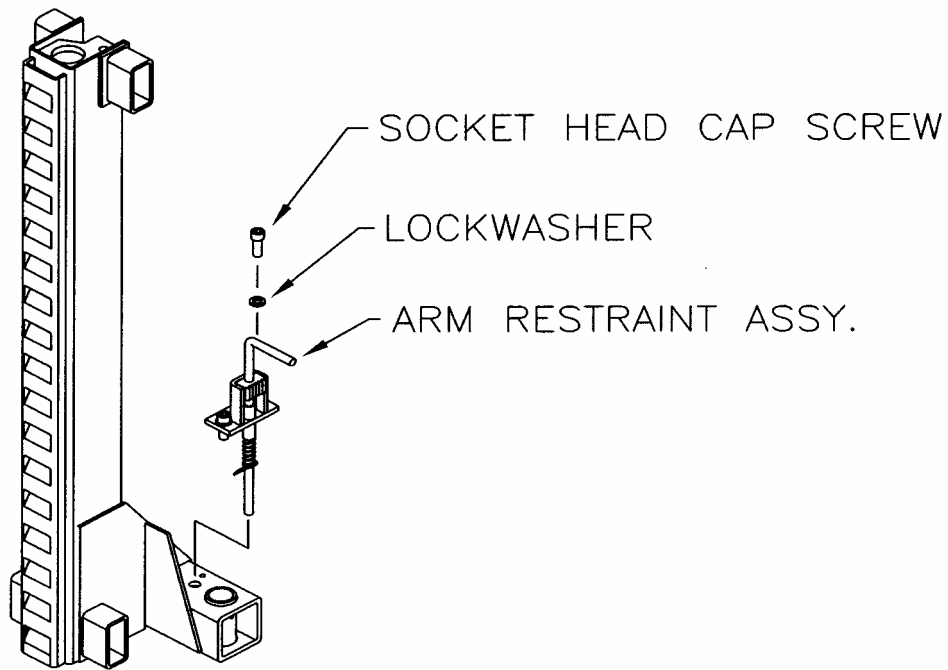

Figure 8 – Arm Restraint Installation

7. Attach the lift pad adapter holders (found in the hardware kit) to the base of each tower (on the back side) using the 1/4" lock washers, and 1/4"-NC x 3/8" round head screws located in the hardware kit.

5.10 HYDRAULIC SYSTEM BLEEDING

1. Run the lift up and down several times to bleed the system.
2. On startup, spray a small amount of lubricating oil into the breather hole at the top of the cylinder. This will help reduce initial friction in the system in case the seals have dried during transport.

5.11 TOWER POSITIONING AND ANCHORING

WARNING! Failure to follow these instructions may cause an unsafe operating condition.

WARNING! Before proceeding with installation, review Section 4: Installation & Tools.

1. Using a 4ft. level on top of the baseplate, shim the base until it is completely level. Ensure that the base plate is completely supported by shims where it does not contact the floor
2. Place 1/16" shims under the bolts at the front of each tower (i.e. to angle the towers outwards). Tighten the 3/4"-NC hex bolts that hold the towers to the baseplate. Using a 4ft. level on the sides of the column, ensure that each column is level front to back. When leveling side to side, the bubble should be at the back of the level because of the shim used to kick the towers outwards.

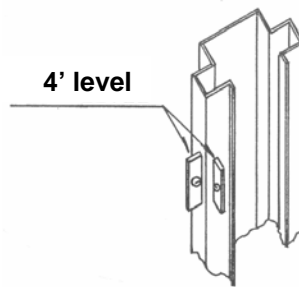

3. Using a rotary hammer drill with a 3/4" masonry drill bit, drill holes in the floor on the high side column using the tower baseplate as a template. Make sure that the 3/4" masonry drill is in good condition (**Figure 9**).
4. Carefully clean out drilling dust from the anchor holes. Hammer in the anchor bolts (**Figure 9**). Hand tighten all anchor bolts.
5. Reconfirm that the column is level front to rear and that it is angled slightly outward side to side. Add or remove shims as required.
6. Torque all anchor bolts to 150 ft-lbs. (203 Nm), continually checking that the column is level as you proceed. If anchor bolts do not tighten to 150 ft-lbs. OR project more than 1 3/4" above the concrete surface (**Figure 9**), the concrete MUST be replaced by an appropriate concrete pad. (*Consult Product Manufacturer / Supplier for further details*).

WARNING! Do not use more than 1/2" (13mm) of shims. Anchor bolts supplied allow for a maximum of 1/2" (13mm) of shim. If more than 1/2" (13mm) of shims are required, **DO NOT** proceed with installation and contact Product Manufacturer / Supplier for further details.

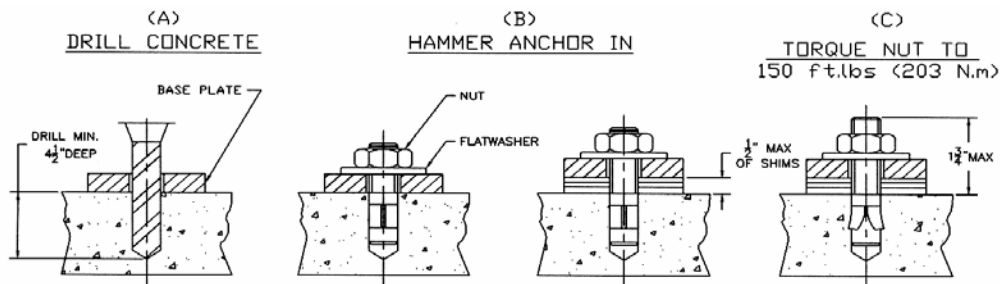











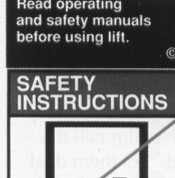



Figure 9 – Anchor Bolts

6 PERIODIC MAINTENANCE

1. Inspect lift daily, to assure the mechanical safety is operating properly.
2. Check the telescopic arms for movement. Clean any grease or oil from the lifting adapters.
3. Raise and lower the lift at the beginning of each shift, without a vehicle on, to verify the lift is leveled and operating properly. Perform hydraulic leveling procedure when the lift is out of level.
4. Lubricate safety dog mechanisms with penetrating oil monthly.
5. Grease arm pins supports monthly.
6. Check hydraulic fittings for tightness.
7. Annual lift inspection as per Automotive Lift Operation, Inspection and Maintenance (ALOIM).
8. Apply a small amount of grease to glide bearing tracks periodically.
9. Check lift for synchronization periodically.
10. Check bolts on carriage stops for tightness
11. Change hydraulic oil every two years.

NOTE: If you are unclear call your local representative immediately.

7 SAFETY AWARENESS - AUTOMOTIVE LIFT INSTITUTE (ALI)

 <p>WARNING</p> <p>Clear area if vehicle is in danger of falling.</p>	 <p>WARNING</p> <p>Position vehicle with center of gravity midway between adapters.</p>	 <p>CAUTION</p> <p>Lift to be used by trained operator only.</p>	 <p>CAUTION</p> <p>Authorized personnel only in lift area.</p>	 <p>SAFETY INSTRUCTIONS</p> <p>Read operating and safety manuals before using lift.</p>	 <p>SAFETY INSTRUCTIONS</p> <p>Proper maintenance and inspection is necessary for safe operation.</p>
 <p>WARNING</p> <p>Remain clear of lift when raising or lowering vehicle.</p>	 <p>WARNING</p> <p>Avoid excessive rocking of vehicle while on lift.</p>	 <p>CAUTION</p> <p>Use vehicle manufacturer's lift points.</p>	 <p>CAUTION</p> <p>Always use safety stands when removing or installing heavy components.</p>	 <p>SAFETY INSTRUCTIONS</p> <p>Do not operate a damaged lift.</p>	<p>The messages and pictographs shown are generic in nature and are meant to generally represent hazards common to all automotive lifts regardless of specific style.</p> <p>Funding for the development and validation of these labels was provided by the Automotive Lift Institute, P.O. Box 33116, Indianatic, FL 32903-3116. They are protected by copyright. Set of labels may be obtained from ALI or its member companies.</p> <p>© 1992 by ALI, Inc. ALIWL014</p>
 <p>WARNING</p> <p>Do not override self-closing lift controls.</p>	 <p>WARNING</p> <p>Keep feet clear of lift while lowering.</p>	 <p>CAUTION</p> <p>Use height extenders when necessary to ensure good contact.</p>	 <p>CAUTION</p> <p>Auxiliary adapters may reduce load capacity.</p>		

Warning Labels for 2-post surface mounted lifts. Daily review of these Safety Messages and Warnings is suggested.

8 PARTS MANUAL

8.1 LIFT ASSEMBLY

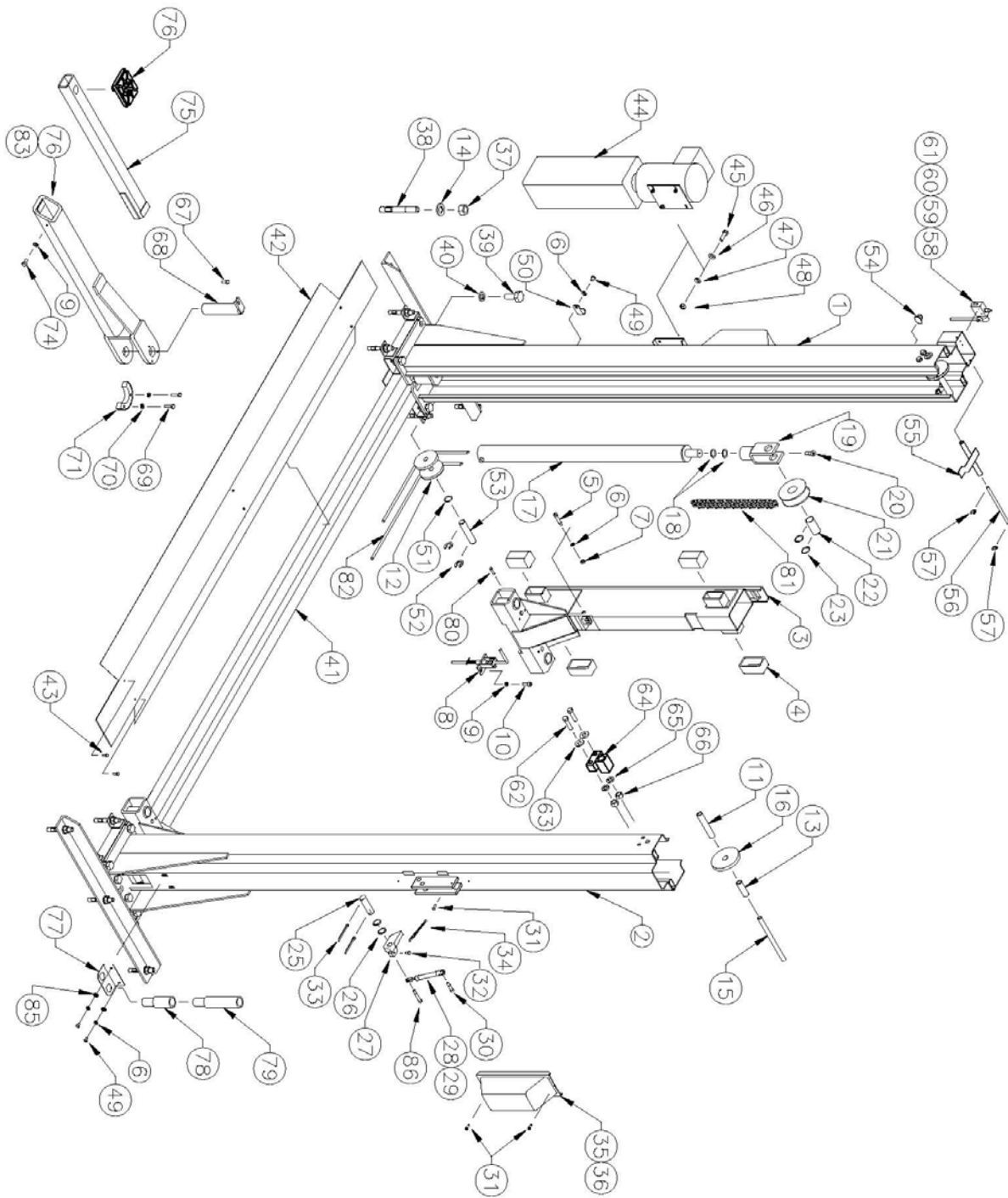

8.2 LIFT ASSEMBLY PARTS LIST

ITEM	QTY	DESCRIPTION	PART #
1	1	TOWER WELDMENT, L.S.	4-0925
2	1	TOWER WELDMENT, R.S.	4-0926
3	2	CARRIAGE WELDMENT	4-0765
4	8	GLIDE BEARINGS	2-0772
5	4	SHOULDER BOLT, 5/16"-NC x 1 1/4"	6-2491
6	7	LOCKWASHER, 1/4" ID	6-0056
7	4	HEX NUT, 1/4"-NC	6-0032
8	4	ARM RESTRAINT ASSEMBLY	1-2038
9	4	LOCKWASHER, 3/8" ID	6-0058
10	8	SOC. HD CAP SCREW, 3/8"-NC x 1 1/4"	6-2048
11	2	PULLEY PIPE, LONG	1-2129
12	4	PULLEY ASSEMBLY	1-2141
13	2	PULLEY PIPE, SHORT	1-2128
14	14	FLATWASHER, 3/4" ID	6-0738
15	2	UPPER PULLEY PIN	1-2126
16	2	PULLEY ASSEMBLY – UPPER	1-2502
17	2	CYLINDER ASSEMBLY	3-0737
18	4	THRUST WASHER	6-0328
19	2	FORK WELDMENT	2-1637
20	2	SHOULDER BOLT, 1/2"-NC x 5/8"	6-0425
21	2	WHEEL CHAIN	2-1854
22	2	FORK PIN	1-2132
23	4	CIRCLIP, 1 1/4"	6-0340
24	2	LEAF CHAIN	1-2424
25	2	SAFETY PIN	1-2337
26	8	FLAT WASHER 51/64" ID x 1" OD	6-0808
27	2	SAFETY DOG	2-0872
28	2	ROD CLEVIS	1-2426
29	2	AIR CYLINDER	1-2425
30	2	SHOULDER BOLT, 5/16"-NC x 3/4"	6-0591
31	6	SELF TAPPING SCREW, #12 x 3/8"	6-2516
32	2	SELF TAPPING SCREW, #10 x 3/8"	6-0169
33	4	SNAP RING 3/4" EXT	6-2445
34	2	SAFETY SPRING	1-1115
35	1	SAFETY COVER C/W DECALS L.S.	0-0865
36	1	SAFETY COVER C/W DECALS R.S.	0-0864
37	14	HEX NUT, 3/4"-NC	6-0737
38	14	WEDGE ANCHOR, 3/4"-NC x 5 1/2"	6-1379
39	12	HEX HD BOLT, 3/4"-NC x 2"	6-2426
40	12	LOCKWASHER, 3/4" ID	6-0259
41	1	BASEFRAME WELDMENT	4-0764
42	1	LINE COVER	2-2015
43	6	SELF TAPPING SCREW, #12 x 1/2"	6-1134
44	1	POWERPACK, 230V / 1PH / 60HZ	6-2055
45	4	HEX HD BOLT, 5/16"-NC x 1"	6-0293
46	4	FLATWASHER, 5/16" ID	6-0295
47	4	LOCKWASHER, 5/16" ID	6-0674
48	4	HEX NUT, 5/16"-NC	6-0294
49	3	ROUND HD SCREW, 1/4"-NC x 3/8"	6-1353
50	1	TUBE CLAMP	6-0536

ITEM	QTY	DESCRIPTION	PART #
51	4	THRUST WASHER, TRA-1220	6-0502
52	4	CIRCLIP, 3/4"	6-2422
53	2	LOWER PULLEY PIN	1-2130
54	4	ELECTRICAL CABLE CLIP	6-1759
55	1	ROCKER ARM	1-2308
56	1	LIMIT SWITCH PIN	1-2427
57	2	CIRCLIP, 5/16"	6-2500
58	1	MICROSWITCH BOX	6-0914
59	1	ELBOW, 90 DEG CONNECTOR	6-0947
60	1	MICROSWITCH	6-0916
61	80"	ELECTRICAL CABLE	8-0030
62	8	HEX HD BOLT, 1/2"-NC x 2 1/4"	6-0315
63	8	FLATWASHER, 1/2" ID	6-0248
64	4	CARRIAGE STOPS	1-2500
65	8	LOCKWASHER, 1/2" ID	6-0059
66	8	HEX NUT, 1/2"-NC	6-0035
67	4	HEX HD BOLT, 5/16"-NC x 3/4"	6-0423
68	4	ARM PIN	2-1594
69	8	HEX HD BOLT, 5/16"-NC x 1 1/4"	6-2059
70	8	FLATWASHER, 5/16" ID	6-0295
71	4	ARM RESTRAINT GEAR	1-2618
72	4	OUTER ARM WELDMENT (FR/RL)	3-0850
73	4	ARM ASSEMBLY C/W PIN (FR/RL)	4-0949-6
74	4	HEX HD BOLT, 3/8"-NC x 3/4"	6-0030
75	4	INNER ARM WELDMENT	3-0742
76	4	ADAPTER PAD ASSEMBLY	1-2634
77	2	ADAPTER HOLDER	1-2012
78	4	3" PAD ADAPTER	1-1993
79	4	6" PAD ADAPTER	2-1580
80	4	GREASE NIPPLE	6-0000
81	2	LEAF CHAIN (CUT TO SIZE)	1-2424
82	2	EQUALIZING CABLE	1-2119
83	2	OUTER ARM WELDMENT (FL/RR)	3-0849
84	2	ARM ASSEMBLY C/W PIN (FL/RR)	4-1075-6
85	4	1/4" FLAT WASHER SAE	6-0060
86	2	HEX HD BOLT 5/16"-18 UNC 1 1/2" LG	6-3253

8.3 HYDRAULIC SYSTEM

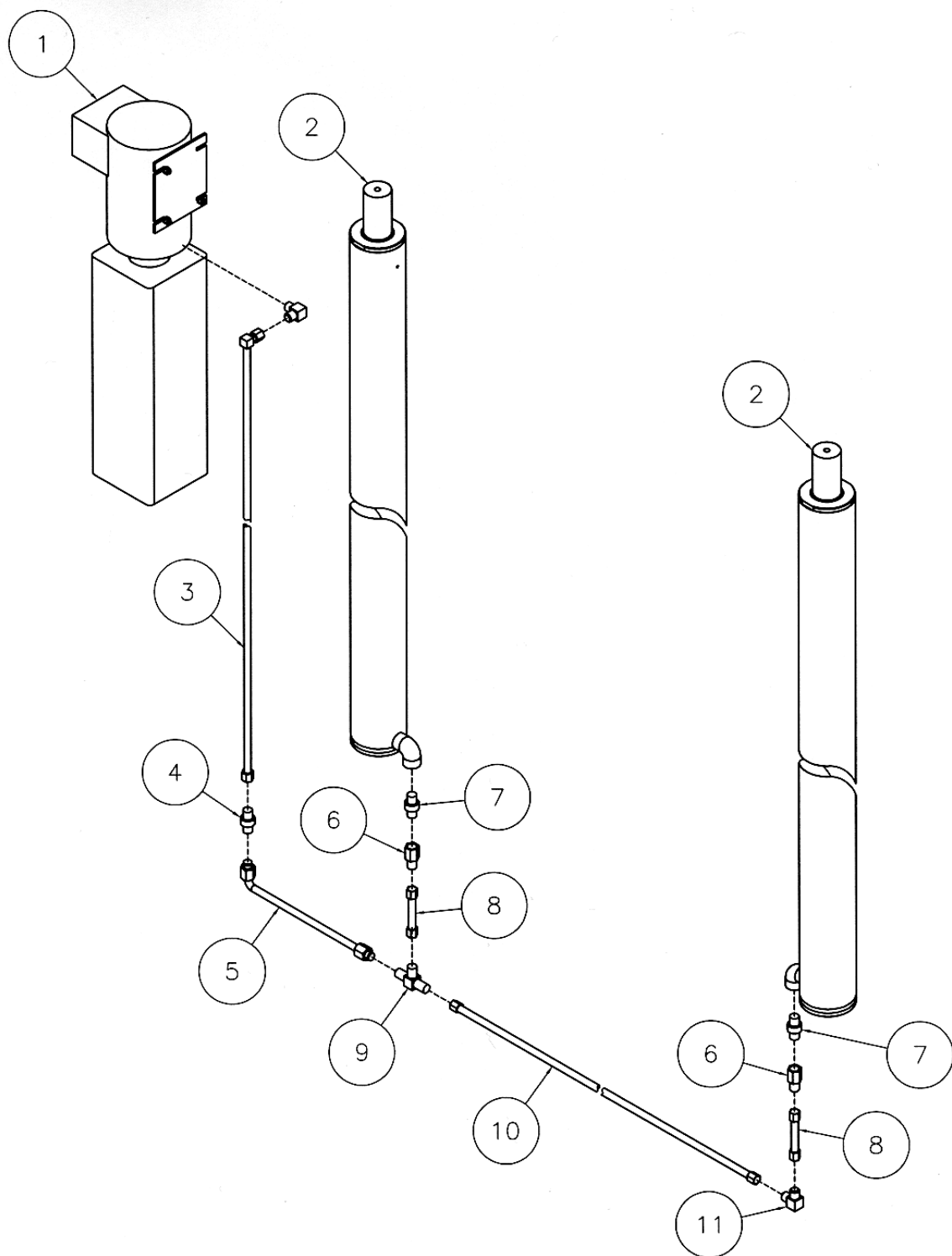

8.4 HYDRAULIC SYSTEM PARTS LIST

ITEM	QTY	DESCRIPTION	PART #
1	1	POWER PACK, 208-230V/1PH	6-2055
	1	POWER PACK, 208-230V/3PH	6-2665
2	2	CYLINDER ASS'Y	3-0737
3	1	HYDRAULIC HOSE ASS'Y	2-1230
4	1	ADAPTER, 3/8" JIC M – 3/8" JIC M	6-0286
5	1	HYDRAULIC TUBE ASS'Y	1-2435
6	2	FLOW CONTROL	6-1510
7	2	ADAPTER, 1/4" NPT M – 3/8" NPT M	6-0270
8	2	HYDRAULIC TUBE, 3/8" OD x 2 5/8" LG	1-0281
9	1	"T" FITTING	6-1372
10	1	HYDRAULIC HOSE ASS'Y	2-1849
11	1	ELBOW, 90° 3/8" JIC M - 3/8" JIC M	6-0922
		<i>3 PH POWERPACK INCLUDES THE FOLLOWING (NOT SHOWN)</i>	
*	1	CONTACTOR BOX (WIRE FOR 3PH)	6-1575
*	1	CONTACTOR BRACKET	2-1130
*	1	COVER PLATE	1-1369
*	2	HEX BOLT, 1/4"-NC x 1" LG	6-0008
*	4	LOCKWASHER, 1/4"	6-0056
*	2	HEX NUT, 1/4"-NC	6-0032
*	2	STRAIN RELIEF	6-0094
*	2FT	CABLE, 14/4	8-0287

8.5 HYDRAULIC CYLINDER

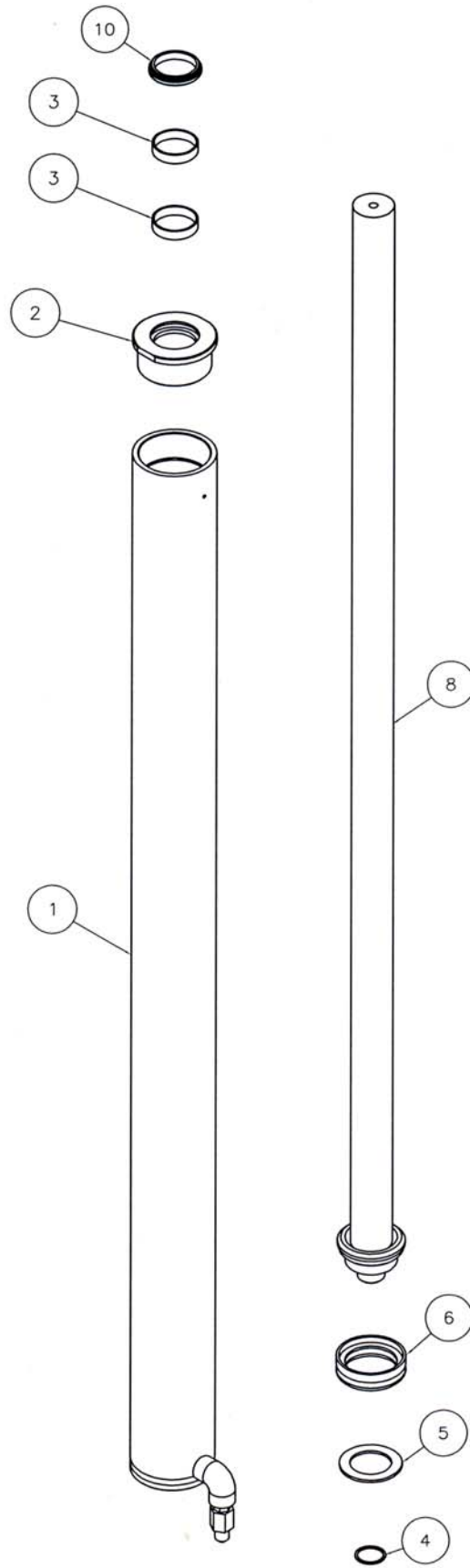

8.6 HYDRAULIC CYLINDER ASSEMBLY – PART LIST

ITEM	QTY	DESCRIPTION	PART #
1	1	CYLINDER TUBE WELDMENT	2-1636
2	1	GLAND	2-1633
3	2	WEAR RING 1 ½” ID X ½”	6-2093
4	1	EXTERNAL SNAP RING	6-0581*
5	1	KEEPER WASHER	1-1148*
6	1	SEAL & WEAR RING 2 ½” OD	6-2915*
8	1	PISTON ROD WELMENT	2-1781
10	1	ROD WIPER, 1 ½” ID	6-0001
		NOTE: PART NUMBERS MARKED WITH AN ASTERIX (*) ARE CONTAINED IN REPAIR KIT NUMBER 0-1287 (1 CYL.) AND 0-1288 (2 CYL.)	

8.7 AIR SYSTEM

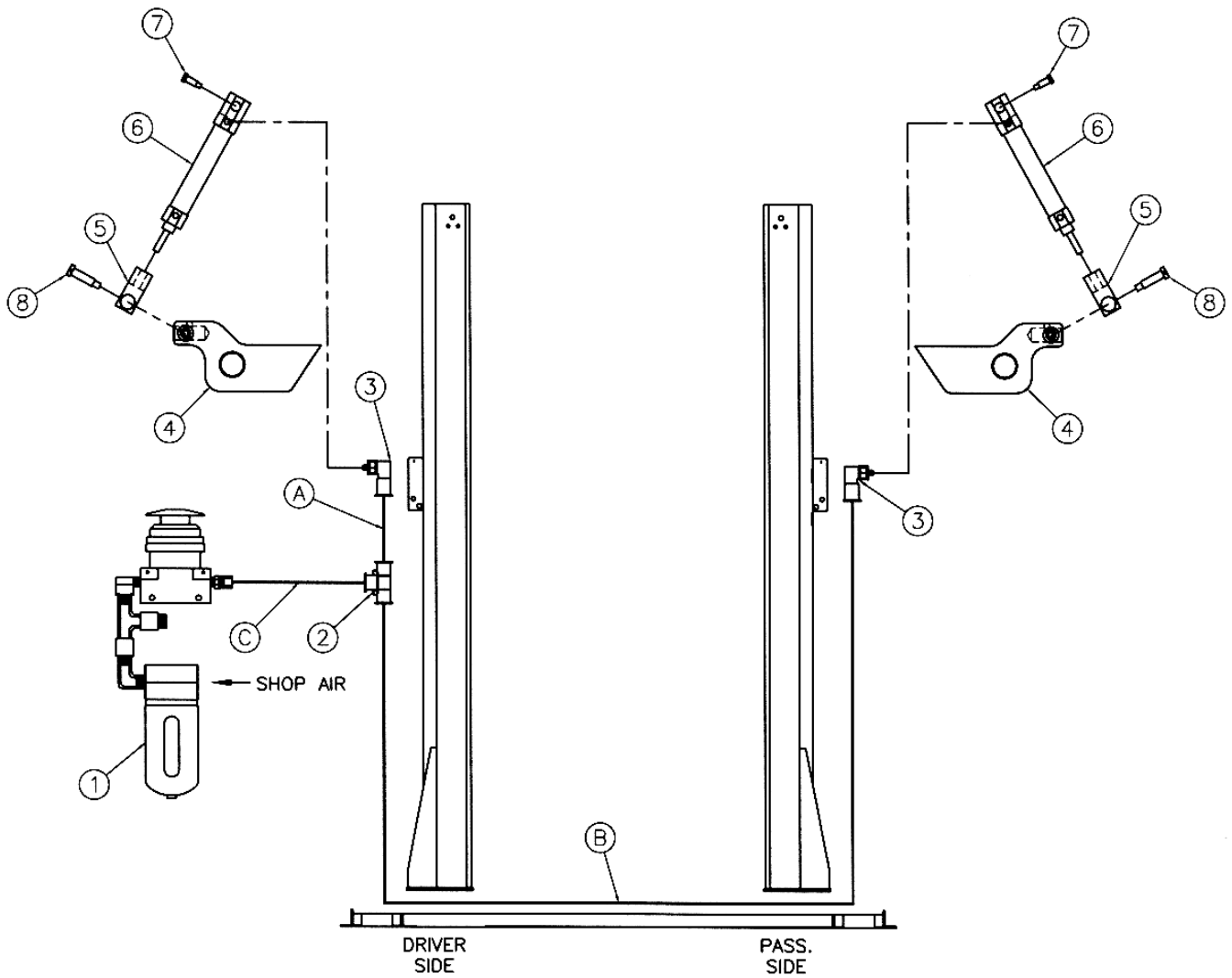

- NOTE:**
- (A) RUN POLYTUBE THROUGH HOLE IN BOTTOM OF SAFETY COVER BEFORE CONNECTING.
 - (B) RUN POLYTUBE UNDER TOWERS AND BETWEEN THE TWO CROSSMEMBER TUBES.
 - (C) CUT A SHORT (APPROXIMATELY 1½") PIECE OF POYTUBE FOR THIS CONNECTION.

8.8 AIR SYSTEM PARTS LIST

ITEM	QTY	DESCRIPTION	PART #
1	1	AIR VALVE & FILTER ASSY	2-1820
2	1	UNION "T"	6-2433
3	2	90 DEG ELBOW, 4mm POLYTUBE TO M5	6-1504
4	2	SAFETY DOG MACHINED	2-1793
5	2	ROD CLEVIS	1-2426
6	2	AIR CYLINDER	1-2425
7	2	SHOULDER BOLT, 5/16" x 3/4"	6-0591
8	2	SHOULDER BOLT, 5/16" x 1 1/4"	6-2491

8.9 POWER PACK:

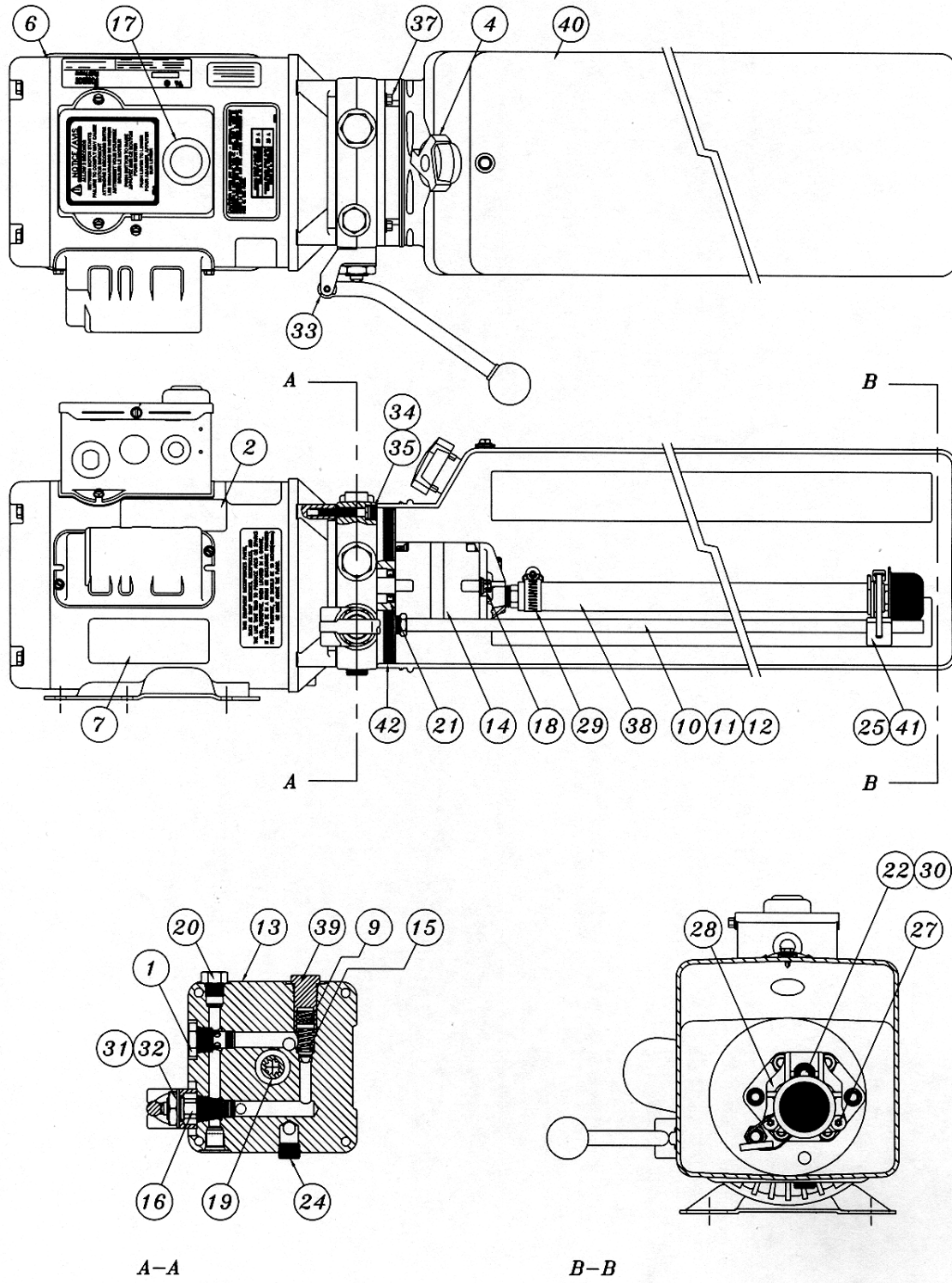

8.10 POWER PACK PARTS LIST:

#6-2055 (AB-1381) 208-230V/1PH/60Hz

#6-2665 (AD-1044) 208-230V/3PH/60Hz

ITEM	QTY.	DESCRIPTION	PART #
1	1	VALVE CARTRIDGE CHECK	6-1087
2	1	LABEL INSTALLATION AUTOHOIST	6-2136
4	1	BREATHER CAP & BLADDER	6-1376
6	1	MOTOR AC 208-230V. 2HP/1PH/60Hz, BLK	6-2474
	1	MOTOR AC 208-230V. 2HP/3PH/60Hz, BLK	6-1079
7	1	LABEL WARNING AUTOHOIST	6-2149
9	1	SPRING 0.480" x 0.063" x 0.42" COMP	6-2151
10	1	RETURN HOSE 3/8" OD x 21.5"	6-2152
11	1	COMPRESSION TUBE NUT	6-2153
12	1	COMPRESSION TUBE SLEEVE	6-2154
13	1	ENDHEAD UNIVERSAL AUTOHOIST	6-2155
14	1	PUMPASSY 2.5 CC/REV. SHORT SPLINE	6-1958
15	1	RELIEF ASSEMBLY FIXED 190 BAR	6-1319
16	1	VALVE CARTRIDGE RELEASE MANUAL	6-0880
17	1	WIRING ASSEMBLY AC 1PH FENNER	6-2473
18	2	BOLT 5/16"-24 x 3.00" TORX G8	6-1090
19	1	COUPLING SAE 9T-20/40 1.260"	6-0774
20	1	PLUMBING PLUG 9/16" SAE	6-2157
21	1	SEAL SHAFT 0.500" x 1.00" x 0.25"	6-2158
22	1	WASHER 0.338" x 0.625" x 0.060" STEEL	6-2159
24	1	PLUMBING PLUG 3/8" NPT	6-2161
25	1	PLUMBING MAGNET	6-2162
27	2	SCREW TAPTITE M6 x 1.0 12MM TORX	6-2164
28	1	COVER ASSY SUCTION	6-2165
29	1	PLUMBING CLAMP HOSE ADJ. INLET	6-2166
30	1	BOLT 5/16"-18 x 1.00" SHCS	6-1392
31	1	NUT 3/4"-16 x 1" HEX x 0.250" STEEL	6-2167
32	1	WASHER 3/4" INT. TOOTH LOCK	6-2168
33	1	BRACKET - HANDLE ASSY REL BLACK	6-0776
34	4	BOLT M6 x 1.0 35MM SOC HD	6-2169
35	4	WASHER 1/4" LOCK HI-COLLAR	6-2170
37	4	BOLT #12-24 x 0.50' HEX WSHRHD	6-1091
38	1	PLUMBING ASSY INLET 17.24 (3)	6-0786
39	1	RELIEF VALVE CAP ASSEMBLY	6-1089
40	1	TANK PLASTIC 6.7 OS 22.50" BLK	6-1399
41	1	CABLE TIE 8" LONG WHITE	6-1846
42	1	O-RING 2-348 BUNA	6-0875

8.11 LIFT MAINTENANCE GUIDELINES – CABLE EQUALIZATION

Two Post Lifts

Safety Instructions

Read operating and safety manuals before using any lift
Do not operate a lift that has been damaged or is in disrepair
Proper inspection and maintenance is necessary for safe operation

General

Check all hydraulic lines and fittings for pinch points, damage, cracks or leaks
Check all electrical wiring for pinch points, cracks or damage
Check all moving parts for uneven or excessive wear
Repair or replace all damaged defective, worn or broken components immediately

Cable Equalized Two Post Lift

- clean and re-grease slide block channels inside of both columns every two months
- grease arm pins every two months
- check and lubricate safety dogs and safety cable adjustment every two months
- dismantle, clean and lubricate arm restraints every two months
- dismantle and clean inner arms every four months
- lubricate cable pulleys every four months
- check equalizing cables and adjust every four months or as required
- change hydraulic oil every two years
- periodically check anchor bolts and re-torque if required

Hydraulically Equalized Two Post Lift

- check and adjust hydraulic level weekly or as required
- clean and re-grease slide block channels inside of both columns every two months
- grease arm pins every two months
- check and lubricate safety dogs and safety cable adjustment every two months
- dismantle, clean and lubricate arm restraints every two months
- dismantle and clean inner arms every four months
- change hydraulic fluid every two years
- periodically check anchor bolts and re-torque if required

Lubrication: Where grease is required > multi-purpose lithium grease
 Where lubricating oil is required > multi-purpose SAE 30 lubricating oil
 Where hydraulic oil is required > ISO 32 10W - non detergent hydraulic oil

